

AUTOCOLLIMATORS

60°-VIEWING/60°-VIEWING WITH DOUBLE MICROMETER

Description:

The function and layout resemble an autocollimator with 90° viewing (see page 46).

The 60°-viewing is used in a horizontal position where the angled eyepiece is more ergonomic. In addition to the standard autocollimator with collimator and eyepiece reticle (see fig. A) versions with mechanical (see fig. B) or digital micrometer (see fig. C) are available as well.

For a general description of the principle of functioning of autocollimators with double micrometer see page 42 or 54, too.

The scale division (SD) of the mechanical double micrometer is 5 μm.

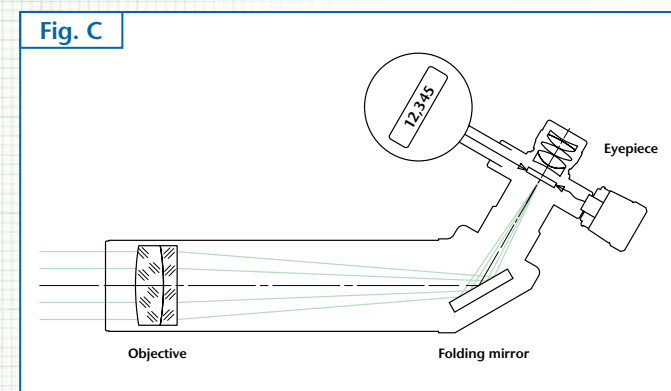
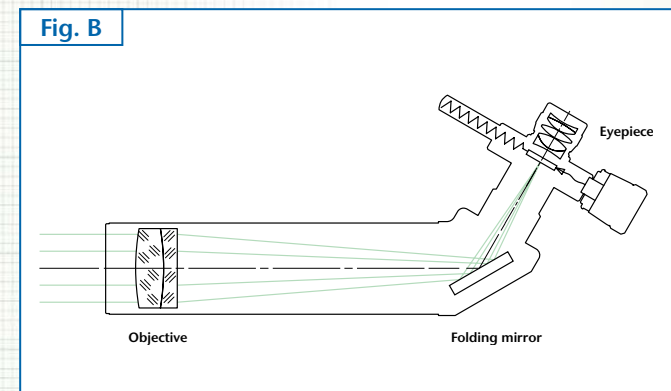
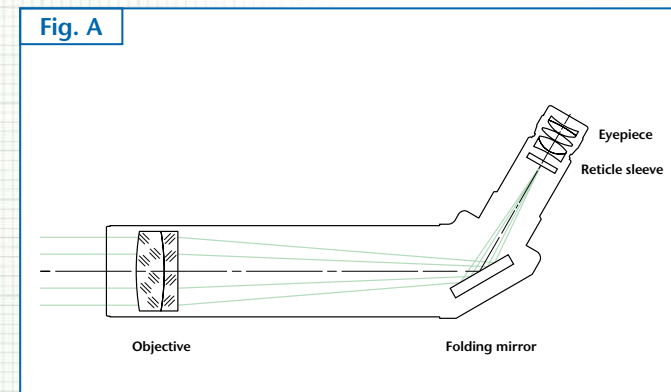

Application areas:

- Measurement of angular tilt
- Measurement of parallelism of plane plates
- Adjustment of optical elements
- Qualitative testing of the imaging properties of optical elements and systems

Notes on ordering:

- Optionally, the autocollimators can be equipped with an eyepiece having 10 mm or 25 mm focal length.
- Two reticles, 6V/5W illumination w/cord, and eyepiece are included.
- If not specified otherwise, the autocollimator is adjusted to infinity at 546 nm wavelength. Adjustment to other distances or wavelengths is also possible on demand.
- Specify the unit of display of the digital gauges (mm, arcsec oder mrad).
- The nomenclature of the autocollimators with 60°-viewing and 60° viewing with double micrometer respectively is as follows:

Example: AK W 300/ 65/ 14,7 MD MDD

Autocollimator
60° viewing
Focal length
Tube diameter
Eyepiece focal length
Double micrometer
Digital double micrometer

Important:

Please specify collimator reticle and eyepiece reticle (see page 82) as well as illumination (LED-, bulb- or cold light, see page 81) when ordering.

60°-VIEWING

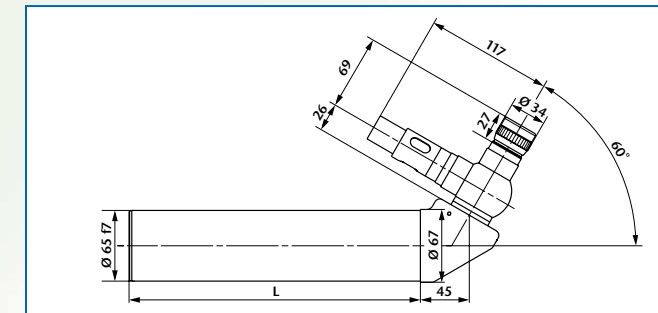

Ord.-No.	Description	Focal length	Free aperture	Meas. range	L
229 027	AKW 300/65/14,7	300	50	1,0°	233
229 028	AKW 500/65/14,7	500	50	0,5°	415
229 030	AKW 500T/65/14,7	500	50	0,5°	233

60°-VIEWING WITH DOUBLE MICROMETER

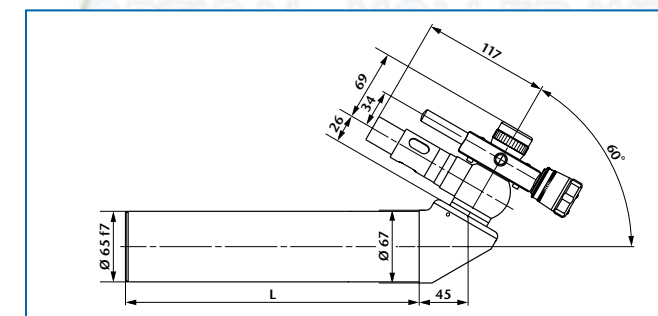

Ord.-No.	Description	Focal length	Free aperture	Meas. range	SD	L
229 169	AKW 300/65/14,7 MD	300	50	0,3°	2,0"	233
229 170	AKW 500/65/14,7 MD	500	50	0,2°	1,0"	415
229 171	AKW 500T/65/14,7 MD	500	50	0,2°	1,0"	233

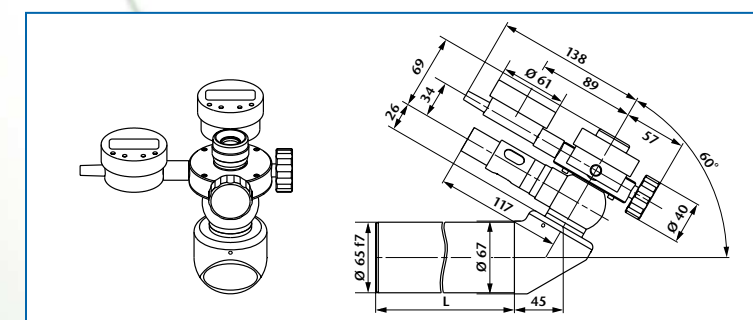

Ord.-No.	Description	Focal length	Free aperture	Meas. range	Resolution	L
229 107	AKW 300/65/14,7 MDD	300	50	0,50°	0,5 arcsec	233
229 108	AKW 500/65/14,7 MDD	500	50	0,25°	0,2 arcsec	415
229 110	AKW 500T/65/14,7 MDD	500	50	0,25°	0,2 arcsec	233