

TESTING TELESCOPES

INTRODUCTION

Layout and principle of operation

A testing telescope provides a magnified real image of a distant object. Usually the object is at infinity at a wavelength of 546 nm. The main components of a testing telescope are:

- objective tube with objective
- reticle sleeve with reticle
- eyepiece

The following figure shows the principle set-up of a testing telescope with straight viewing adjusted to infinity. The reticle is positioned at the rear focal plane of the objective. Due to this configuration all objects at infinity are imaged into the reticle plane. The reticle plane is viewed through the eyepiece. Due to this set-up the image in the eyepiece is rotated by 180°.

Mechanical and optical axes of testing telescopes with focal length $f \leq 300$ mm are adjusted with an accuracy of $\pm 30 \mu\text{m}/f$.

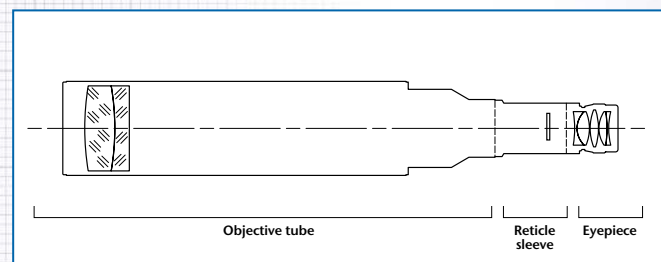

Testing telescopes form with collimators a measuring system for direction and angle testing of optical elements or optical systems in transmission.

Calculation of the angles

The angles (α_x and α_y) can be calculated from the distances Δx or Δy of the image of the collimator reticle to zero position of the eyepiece reticle as follows:

$$\alpha_x = \arctan\left(\frac{\Delta x}{f}\right) \approx \frac{\Delta x}{f}$$

$$\alpha_y = \arctan\left(\frac{\Delta y}{f}\right) \approx \frac{\Delta y}{f}$$

f : focal length of the telescope objective

Numerical example:

A displacement of 3 mm measured with a testing telescope with 300 mm focal length corresponds to an angle of:

$$\alpha \approx 3/300 \text{ rad} = 10 \cdot 10^{-3} \text{ rad} = 0,5730^\circ = 34'23''.$$

A point at a distance of 10 μm to the centre of the eyepiece reticle corresponds to an angle of the parallel beam to the optical axis of the telescope as follows:

Focal length	Angle
50 mm	41"
90 mm	23"
140 mm	15"
200 mm	10"
300 mm	6,9"
500 mm	4,1"
600 mm	3,4"
1100 mm	1,9"

Adjustable Focus

Besides testing telescopes with fixed distance between reticle and objective telescopes with adjustable focus are available. With these telescopes the distance between reticle and objective is adjustable. If the reticle is displaced out of the focal plane by a distance z' , then the telescope is focused at a distance a according to:

$$a = \frac{f^2 + z'f}{z'}$$

$z' < 0$ corresponds to a decrease of the distance between objective and reticle. The resulting image distance is negative (virtual object position) (a).

$z' > 0$ corresponds to a real image with positive object distance (c). $z' = 0$ produces an image at infinite distance (b).

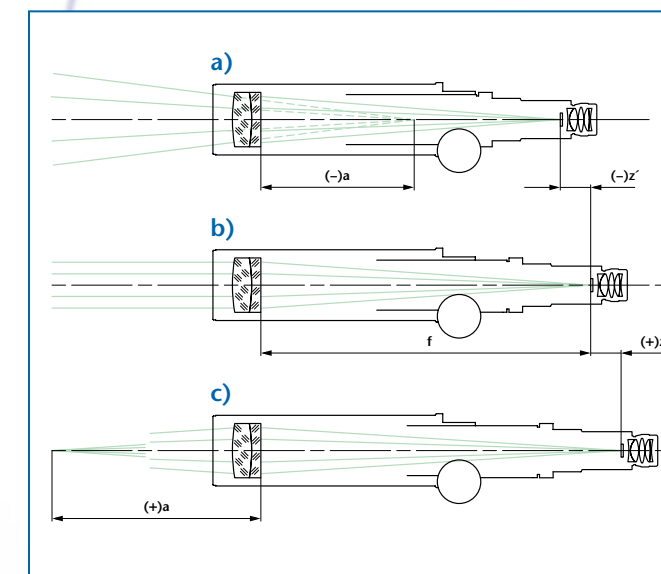

Selection criteria

Long or short focal length?

Depending on the magnification of the instrument a longer focal length leads to a greater measuring sensitivity and measurement accuracy. As the focal length increases, the measuring range (FOV) decreases proportionally. Additionally, the intensity of the light bundle received by the telescope decreases with increased focal length. A longer focal length affects the mechanical extension of the tube, as well.

Small or large objective aperture?

Light conditions are more favourable when large apertures are used, and the evaluation of the results is easier and more accurate. A long distance between test specimen and telescope demands a relatively large free aperture (or aperture ratio). For these measurements a relatively large aperture diameter should be used.

Fixed or variable distance setting?

Fixed, infinity focus testing telescopes are generally the best choice when testing systems adjusted to infinity. Fixed focus tubes set at other than infinity can be ordered.

For measurement tasks requiring an adjustable focal distance like adjustment at different wavelengths or to different distances, focusable testing telescopes with objective tube with tube extensions are used.

Eyepiece focal length?

Usually eyepieces with $f=14,7$ mm are used. Eyepieces with $f=10$ mm give greater magnification but less field angle. Eyepieces with $f=25$ mm give larger field of view but less magnification. For eyepieces with $f=14,7$ mm and $f=25$ mm a C-Mount Camera adapter is available.